

# LMSSC PACKAGING STANDARD

**P-106**  
Revision 2  
Page 1 of 5  
04-15-2009

---

---

## **1.0 SCOPE**

This standard provides for the preservation and packaging of antifriction bearings/bearing assemblies.

## **2.0 REFERENCES**

- 2.1 Lockheed Packaging Standard LPS 40 001 (General Requirements Specification)

## **3.0 REQUIREMENTS**

### 3.1 GENERAL

- 3.1.1 Unless otherwise specified, the quantity per unit package shall be one (1) each or one set (as applicable).  
\_\_\_\_\_ : For exception see miniature bearing packaging (Ref Paragraph 3.2.4).
- 3.1.2 When specified in the procurement document, specification/ drawing, bearings shall meet the environment/process cleanliness requirements of MIL B

3.2.5.2 Place preserved/wrapped bearing in a water vaporproof bag conformal to MIL B 131, Class I, or MIL PRF 22191, Type I, Class 1. Include cushioning as required to protect the bearing and close bag by heat sealing.

\_\_\_\_\_ : Allow sufficient excess material to permit at least two additional heat seals.

3.3 INTERMEDIATE PACKAGING (Consolidation of unit packages, when applicable)

3.3.1 Unless otherwise specified, the number of unit packages per intermediate container (containing identical parts) shall be limited to the dimensions and gross weight provisions of the container specification (Ref Carrier Regulations).

3.3.2 Fill all voids with suitable dunnage, blocking or bracing to prevent damage during handling/shipment.

3.4 PACKING

3.4.1 Pack appropriate number of intermediate containers uniformly into each shipping container.

3.4.2 Shipping containers as packed shall protect the item from damage during ordinary handling/shipping and shall meet the minimum requirements of common carriers for safe transportation at the lowest rate to the point of delivery.

3.4.3 Unit or intermediate containers which meet the requirements of Paragraph 3.4.2 may be used as shipping containers.

3.4.4 Enclose or attach a copy of packing slip to the shipping container.

3.5 MARKING (Unless otherwise specified in the contract or Purchasing Document use the following criteria)

3.5.1 Unit Package Marking Label or mark each package, compartment, or blister (as applicable), to show at least the part number per contracting document, quantity, and supplier identity. Additional markings may be specified in the item detail specification or drawing.

3.5.2 Intermediate Packaging Marking Label or mark each container to at least show part number per contracting document, supplier and quantity of parts.

3.5.3 Shipping Container Marking Label or mark each container to show part number per contracting document, the LMSSC contracting document number, supplier, destination and quantity of parts.

3.5.4 Special, precautionary and handling markings shall be applied as required.

**4.0 QUALITY ASSURANCE**

4.1 Packaging shall be accomplished in such a manner as to prevent physical damage to, or degradation of, the packaged items during delivery to the using activity. It shall be the prerogative of LMSSC to return damaged items, at supplier's expense, when such damage is attributable to improper or inadequate protection.

## **5.0 NOTES**

5.1 The following information is intended as a guide or aid to suppliers in meeting the requirements of this specification.

### 5.1.1 REFERENCES

Barrier, Greaseproof/Waterproof	MIL B 121
Barrier, Greaseproof/Heat Sealable	MIL PRF 22191, Type 1, Class I
Barrier, Water Vaporproof	MIL B 131, Class 1
Barrier, Water Vaporproof	MIL PRF 22191, Type 1, Class 1
Bearings, Antifriction	MIL B 197
Box, Corrugated	ASTM D5118, Type CF, Class Domestic, SW (optional), Style RSC, Grade 44 ECT or 200 Mullen (optional)
Box, Folding	PPP B 566
Box, Metal Stayed	PPP B 665
Box, Setup	PPP B 676
Cushioning, Cellulosic	A A 1898, Grade 1, Class C, Style 1, Size L.PT.5 59 0 T0 Tc Tfw .5616 0 TD (A)T

**P-106**

Revision 2

Page 4

04-15-2009

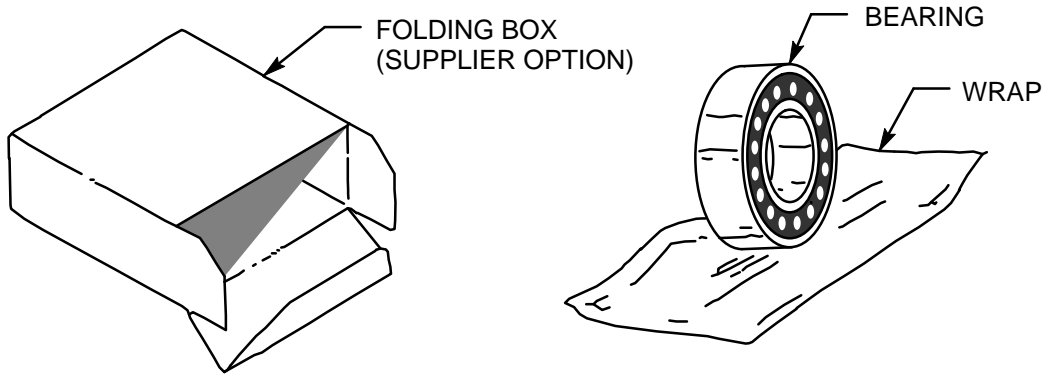

Figure 1. Unit Package Type 1

P10131-001

